



**INSTALLATION
INSTRUCTIONS &
WARRANTY GUIDE**

IMPORTANT



CONTENTS

DELIVERY	3
STORAGE	3
DOOR INSTALLATION.....	4
INSTALLATION WITH SIDELIGHTS	5-6
INSTALLATION WITH FANLIGHTS.....	6
STRUCTURAL CAVITY CLOSERS.....	7
HINGE ADJUSTMENTS.....	7
LOCK AND KEEP ADJUSTMENTS	7
AFTERCARE AND MAINTENANCE	8
WARRANTY PERIOD	8
REPORTING A WARRANTY ISSUE.....	9
KEY CONTACTS	10



DELIVERY

- All discrepancies, damaged or missing items must be identified and reported in writing within 48 hours of the delivery date. Failure to do this could result in your claim being rejected.
- All pre-hung door sets will be delivered with the ironmongery and furniture attached to the frame. It is your responsibility to check all items have been received before signing the delivery sheet. If there are any items missing, this needs to be reported within 48 hours of the delivery date.
- Never slide or drag the pallet or doors as this may damage the doors surface or hardware.
- Take care not to drop the door on a corner, this may warp and distort the door.
- Ensure the pallet is offloaded and placed on flat level ground. Any distortion may twist or bow the door making them unsuitable for installation.
- The offloading of the delivery vehicle on site is the customers' responsibility. Bowater Doors cannot take responsibility for any damage during the offloading process.

STORAGE

PLEASE NOTE THE WARRANTY STARTS FROM THE DELIVERY DATE.

- **DOORS MUST** be taken off the pallet and stored in an upright position, the right way up and no more than three deep.
- **DOORS MUST** be immediately stored inside prior to installation in the conditions outlined above. Doors stored outside will not be covered by the Bowater Doors warranty.
- **DOORS MUST** be stored in a well ventilated building/container and protected at all times from moisture and extremes of temperature.
- **DO NOT** store doors near to where gas heaters are used.
- **DO NOT** store in unventilated containers.
- **DO NOT** store on top of containers.
- **DO NOT** store where wet trades are being carried out, doors exposed to moisture may swell, split or become twisted and distorted.
- **ALWAYS** ensure adequate protection between each door. It is vital to ensure no contact is made between each door that may result in surface damage or broken glass on glazed doors.

DOOR INSTALLATION

1. Pre-check door(s) for any sign of physical damage.
2. Remove the keys and handle pack attached to the side of the frame.
3. Ensure the sill is supported and sealed.
4. **CHECK THE DOOR FRAME IS LEVEL AND PLUMB THROUGHOUT THE FITTING PROCESS.**
5. Our doors are supplied with a Part M compliant threshold. These will arrive as a goal post or on a sill (composite, timber or UPVC). These thresholds are secured to the sill and sealed at our factory, however if you have asked for them to be supplied unfitted, please ensure you re-seal with two full lengths of silicone prior to fitting. Take care not to block up the three 6mm drainage holes with silicone or debris (point **E**) and maintain a drainage channel (point **F**).
6. Ensure the standard opening is a minimum 10mm wider than the frame in width and height. Under no circumstances should a door be fitted into a standard opening that is too small.
7. Place the frame within the door aperture with the aid of non-compressible shims at both jambs and centralise to ensure the door frame is still level and plumb on the hinge side (lock and jamb can be adjusted within tolerances).
8. Using concrete/masonry torx screws, direct fix the frame into masonry or use a structural cavity closer (recommended when fixing into an open cavity). Start from the top of the frame and ensure there are two fixings one above and one below each hinge. All fixings should achieve a minimum structural penetration of 60mm (see points marked **DF**).
9. Check the gap between door and frame for uniformity, with particular attention to the lock jamb and sill. Adjust the frame if necessary. Some resistance should be apparent at the threshold seals.
10. The gap between the top of the door and frame should be level and uniform and between 2-4mm.
11. Adjust the frame keeps to create compression against frame seal (see keep adjustment on page 7).

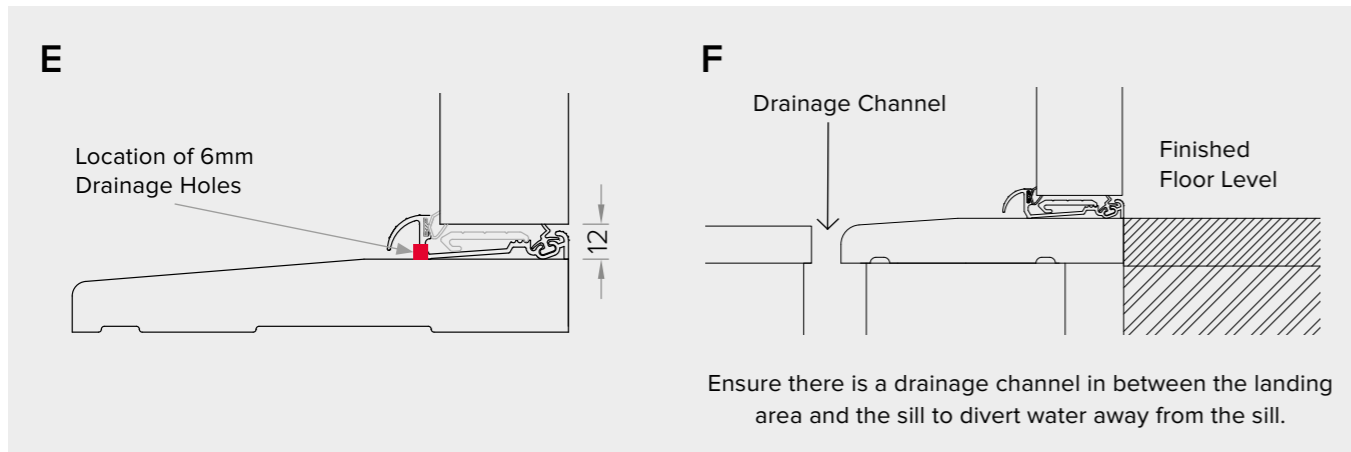
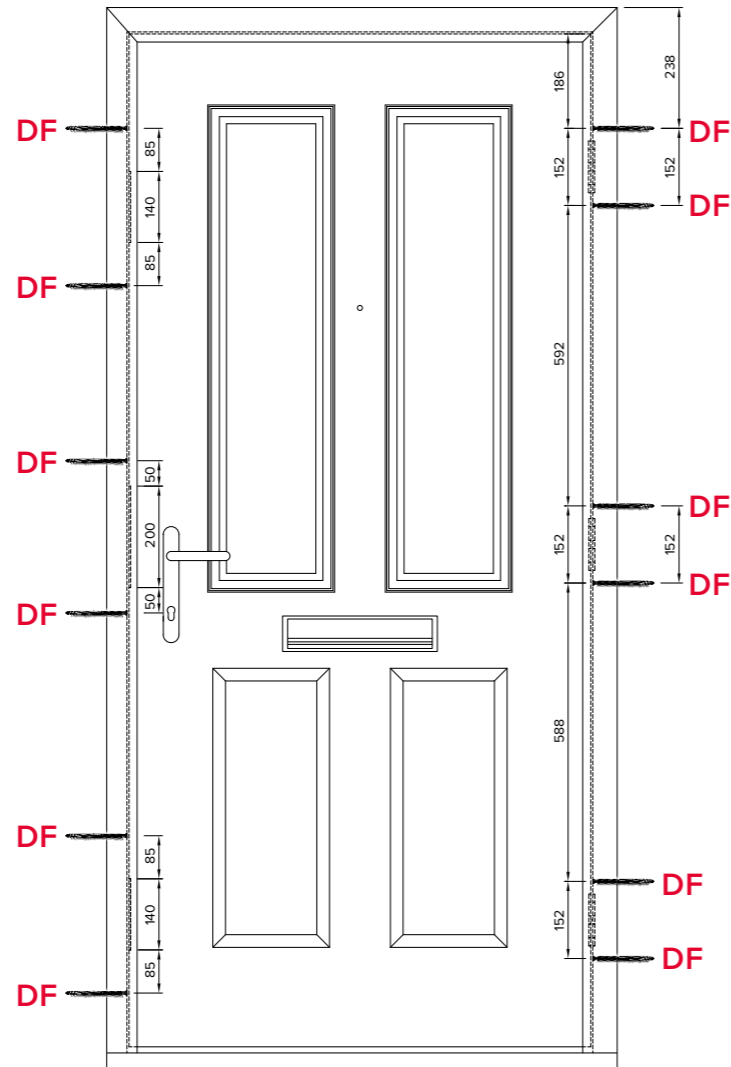

INSTALLATION WITH SIDELIGHTS

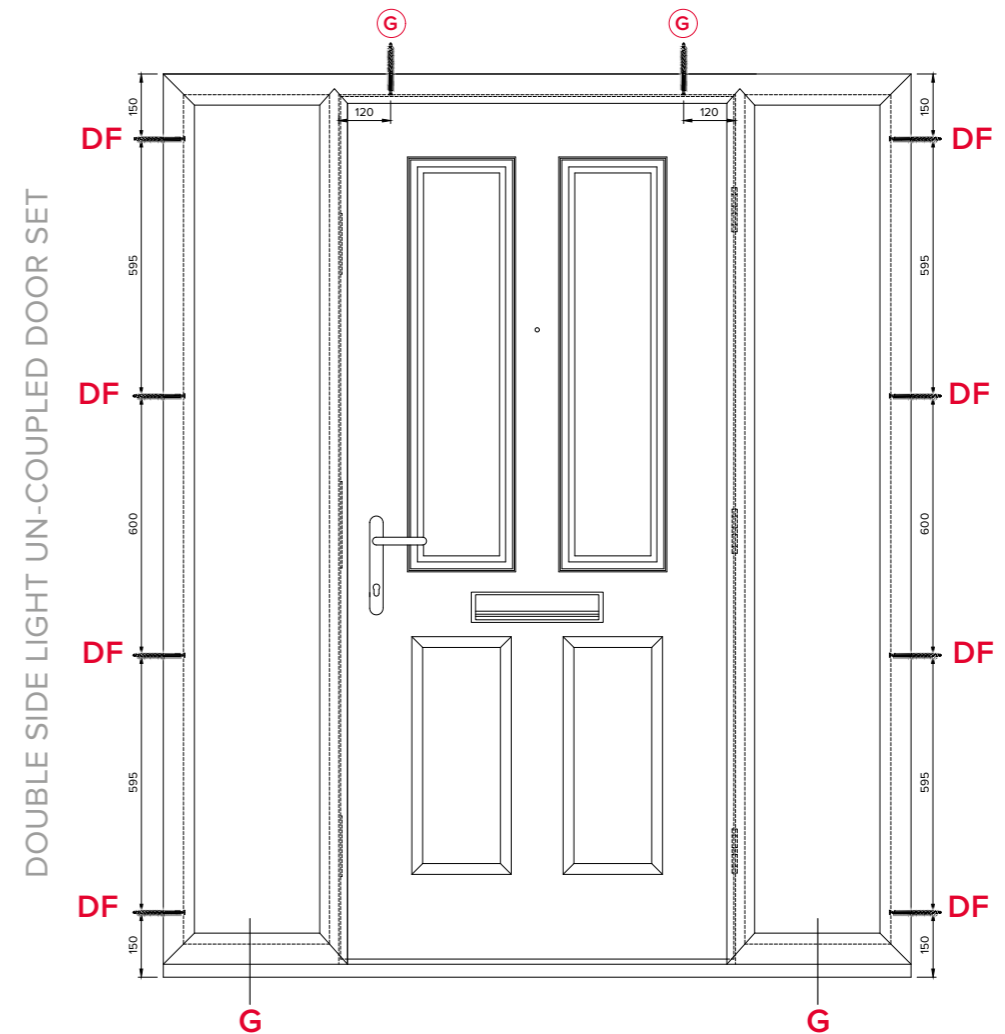
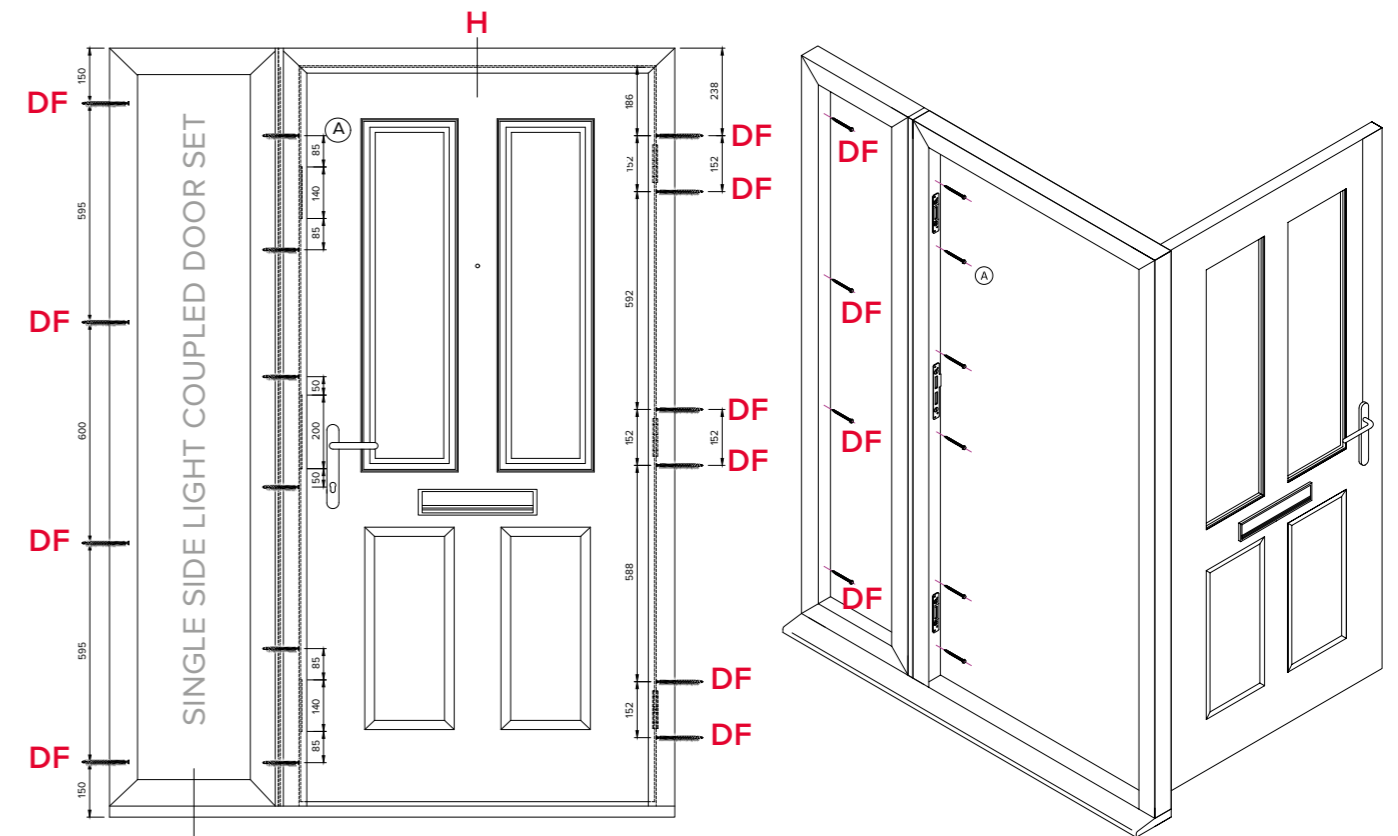

INSTALLATION WITH SIDELIGHTS

Follow the standard door fitting installation instructions to point 5 (page 4) and finish with the points below. Un-coupled side lights are delivered as a complete unit. Coupled sidelights need to be fixed together on site.

- De-glaze the side light frame prior to fixing:
 - Gently remove the two vertical beads followed by the horizontal beads with a glazing or putty knife, take extra care not to damage the bead.
 - Carefully remove the glazing, identify and take note of the external laminated side, you will need to know this for re-fitting the glass.
 - Once the side light is fully de-glazed, ensure the frame is plumb and level by packing evenly at the jambs and each fixing point using non-compressible shims.
 - Timber framed sidelights are not sealed.
- We recommend that the sidelight and frame should be temporarily clamped when fixing. Using self-drilling screws (not supplied by Bowater Doors), fix the door frame to the coupled sidelight at six points through the aluminium bar attached to the glazed section as per point A.

- Secure the frame using non compressible shims. Once in place, use concrete/masonry torx screws (not supplied by Bowater Doors) to direct fix the **straight and plumb** frame at **points marked DF**. Start fixing from the top to the bottom at 40-50mm above and below the middle and top hinges.
- For double sidelight frames direct fixings should be applied one at the top of the door and one in each sidelight "where possible" to provide central rigidity (point G).
- For a single sidelight direct fixings should be applied one at the top of the door and one at the bottom of the sidelight "where possible" to provide central rigidity (point H).

Continue to follow the standard door fitting instructions (page 4) from point 5 to complete the installation.

Bowater Doors recommend de-glazing all side lights prior to installation.

INSTALLATION WITH FANLIGHTS

- De-glaze the side light frame prior to fixing:
 - Gently remove the two vertical beads followed by the horizontal beads with a glazing or putty knife, taking extra care not to damage the bead.
 - Carefully remove the glazing, identify and take note of the external laminated side, you will need to know this for refitting the glass.
 - Once the fan light is fully de-glazed, ensure the frame is plumb and level by packing evenly at the transom and each fixing point using non compressible shims. The packing must be at each side of the transom and not in the middle to secure the glass and keep it square (see points marked i).
- Secure the frame using non compressible shims. Once in place, use concrete/masonry torx screws (not supplied by Bowater Doors) to direct fix the straight and plumb frame to the top of the opening.

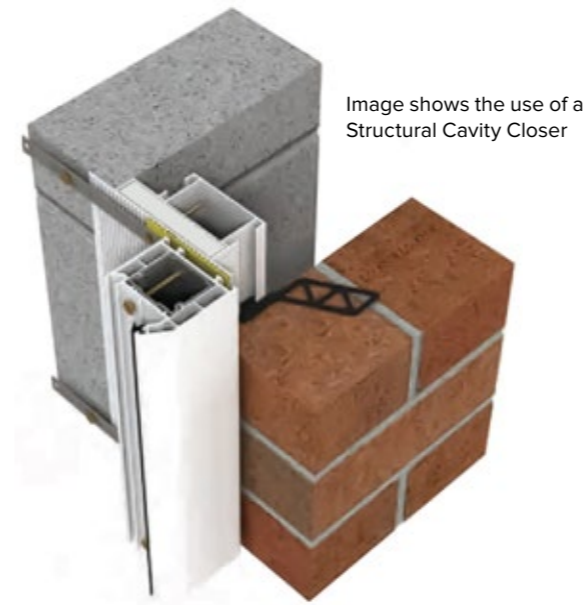
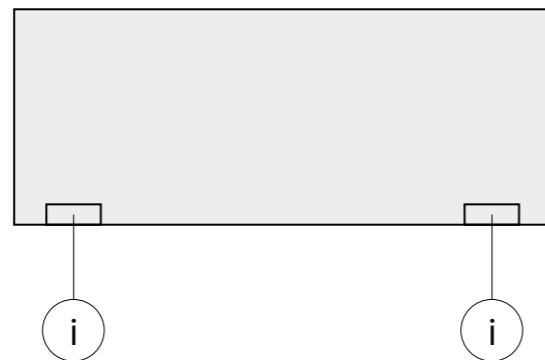

STRUCTURAL CAVITY CLOSERS

The use of a Structural Cavity Closer in all open cavity installations allows a solid fix of the frame. This allows a direct fix through the outer door frame into the cavity closer. As a result, it minimises any movement that may occur once the door has been installed.

- 100mm, 125mm and 150mm versions are available.
- Acts as a damp-proof course (DPC).
- Structural Cavity Closers can be purchased direct from Bowater Doors.

Please contact the sales office for installation instructions.

Figure A

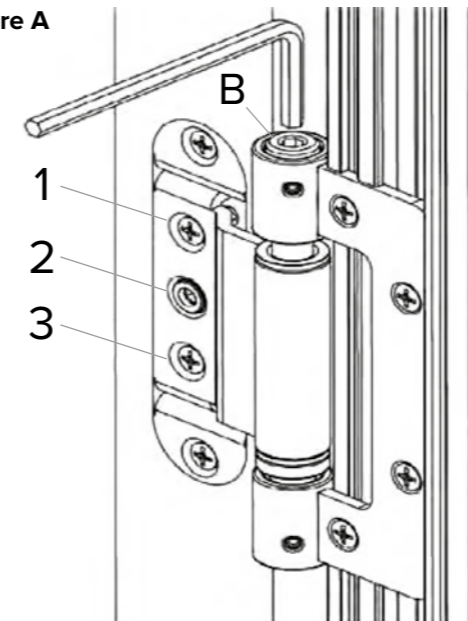

HINGE ADJUSTMENTS

Horizontal Adjustment:

- Loosen screws 1 and 3 by three turns.
- Tighten or loosen Allen Screw 2 with a 4mm Allen Key.
- Tighten screws 1 and 3.

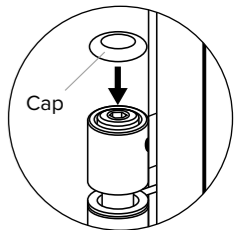

Height Adjustment:

- Turn Allen Screw B with a 4mm key.
- Key as shown in **Figure A**. Adjustment: -2/+6mm.
- Ensure you adjust all three bearings for height to maintain correct load bearing.

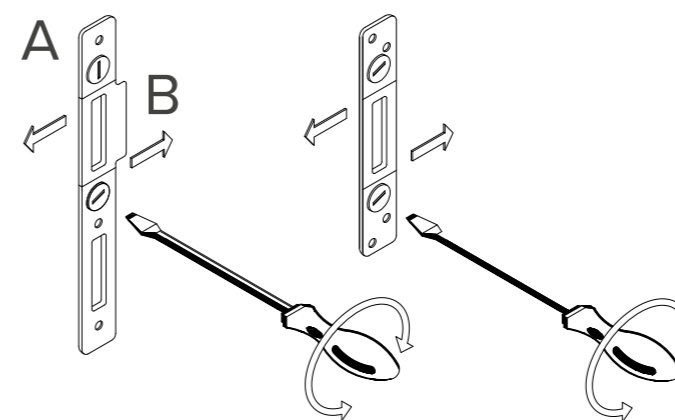

LOCK AND KEEP ADJUSTMENTS

The central keep should be adjusted first, the top and bottom keeps should be adjusted if required. To increase compression move the keeps towards 'A'. To reduce compression move the keeps towards 'B'.

For instructions on how to fit a timber frame, please contact our technical team: door.customerservice@birtleygroup.co.uk

AFTERCARE AND MAINTENANCE

- Fittings on Bowater Doors are coated with a hardwearing clear lacquer to prevent tarnishing and discolouring.
- When closing the door, the lock should always be engaged by pulling the handle up - failure to do so could cause the lock to fail and the door to bow.
- To prolong the life of the furniture, glass and paint finish to the door, regular dusting with a soft, clean cloth, supplemented by occasional washing with warm soapy water is recommended.
- Under no circumstances should metal polishes, abrasive cleaners, chemicals or other cleaning solvents be used as this will remove the protective lacquer coating.
- Moving mechanisms should be lubricated with a light oil or silicone spray after installation, at least once a year.
- If the door is removed from the frame, it should be stored on edge to avoid damaging the weather strip.

WARRANTY PERIOD

The **customer*** is granted a warranty covering the safe and reliable function of a Bowater Door.

The warranty period of the component parts begins from the date of delivery and is stipulated as:

RETAIL DOORS (68MM DOUBLE REBATE)

COMPONENTS	WARRANTY PERIOD
Slab	10 years
Paint/Stain	5 years
Glass	10 years
Lock	5 years
Ironmongery Finishes	2 years

RESIDENTIAL DOORS (44MM)

COMPONENTS	WARRANTY PERIOD
Slab	2 years
Paint/Stain	2 years
Glass	2 years
Lock	2 years
Ironmongery Finishes	2 years

All warranty issues are to be reported through our website at:

bowaterdoors.co.uk/reporting-a-warranty-issue/

Please note, if the requested information and relevant images are not supplied your warranty claim will NOT be processed.

Bowater Doors guarantees that from the date of delivery and whilst the original occupier remains in the premises of the installation, it will, in accordance with the warranty schedule, repair or replace components or materials that prove to be defective. Bowater Doors do not cover any warranty issues associated with incorrect installation, maintenance and delivery.

***The customer is defined as the direct customer of Bowater Doors, not the end user/consumer.**

REPORTING A WARRANTY ISSUE

EMERGENCY ISSUES

In situations where you are unable to enter/exit the premises and you are not able to wait for an assigned engineer visit, you can call an emergency locksmith to carry out the work. You will still need to log the warranty claim and attach the locksmith's report and invoice.

This warranty log allows you to claim up to £150.00 + VAT for the callout. It is advised that you contact our team before calling out a locksmith to ensure the callout is covered under our emergency issues.

Please note: Bowater Doors is not liable for any damage caused by a third party whilst carrying out work on our products.

If you feel that the product is defective and that the issue is not associated with delivery, storage, installation or adjustment, as detailed in this document, please visit the Bowater Doors website to submit your claim.

Please note any modification to your door, for example installation of a pet door, will invalidate your warranty and your claim will not be processed.

We require all of the requested information to be filled in on this form to identify the original order and plot number. If the information is not filled in we will not be able to process your claim.

PROCESSING WARRANTY CLAIMS

Bowater Doors will use the supplied information to open the investigation for your claim. The investigation will determine if replacement component parts are required to be sent out to you or whether an engineer visit is needed.

TECHNICAL HELP AND ASSISTANCE

We offer technical assistance via email, telephone call, and video call. You can request a call through our warranty team to allow our engineers to identify and potentially resolve the issue remotely without any charge.

ENGINEER SITE VISITS

When submitting a claim you will be asked for a purchase order number for the visit. If, after the site visit, the issue is found to be a result of delivery, storage, installation or adjustment, a charge of £150.00 + VAT will be collected and your warranty claim may be rejected.

A detailed engineers report will be available after inspection. If the issue is found to be the result of installation the Bowater Doors Engineer will attempt to make appropriate adjustments, however the engineer will not refit the doorset. Regardless of any remedial works the visit is still chargeable at £150.00 + VAT + the cost of any parts used.

Please note: the customer is responsible for all arrangements with the end user. If for any reason there is no access to the property the call out charge will apply.

PLEASE NOTE, BOWATER DOORS DO NOT ACCEPT CONTRA CHARGES UNDER ANY CIRCUMSTANCES.



Bowater Doors Ltd, Mary Avenue, Birtley, County Durham DH3 1JF
T: 0191 410 6631
door.sales@birtleygroup.co.uk | www.bowaterdoors.co.uk

The particulars of this brochure are for guidance only. We operate a policy of continuous improvement and individual features may vary from time to time. Precise information should always be requested from our technical department. Birtley Group cannot be held responsible for any errors or omissions contained in this brochure.
BDL01 April 2024

